

MAINTENANCE

WARNING: Unplug the power cord before starting this procedure.

Replacing the Heating Element

1. Disassemble the Heating element cover, securing nut, nozzle and filter pipe assembly .
2. Unscrew fastening screws and separate the housing.
3. Detach the terminal and remove the heating element.
4. Insert a new heating element and reassemble (Heating element 24V-40W).

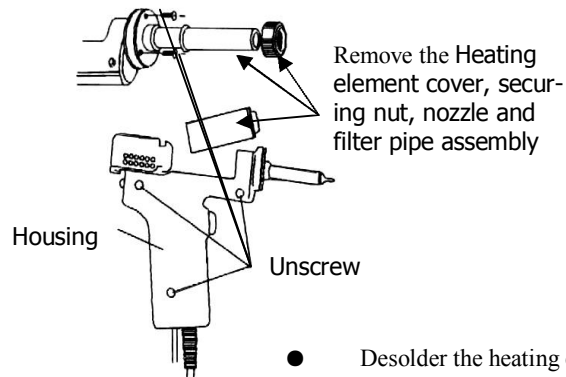

- Desolder the heating element leads and sensor leads.
- Remove the old heating element and replace if with a new one.
- There is no polarity between leads of the same colors.
- Bend the leads at right angle to prevent short-circuit.

AOYUE®

De-soldering gun

INSTRUCTION MANUAL

Warning: Items are extremely hot and should be used with great care and caution, damage to person and property may occur if items are not handled properly.

MAINTENANCE



CAUTION:

The desoldering gun will be extremely hot. During maintenance, please wear proper protection and work carefully.

Cleaning the nozzle/ barrel.

1. Turn on the desoldering gun and wait for the nozzle to heat up.
2. The cleaning pin will not pass through the nozzle until the solder inside the nozzle is completely melted.
3. If the cleaning pin does not pass through the hole in the nozzle, clean with the cleaning drill.
4. Slowly insert the cleaning pin while turning the cleaning pin clockwise.
5. Pull out the cleaning pin in a straight motion.
6. Repeat steps 4-6 until clog is removed.

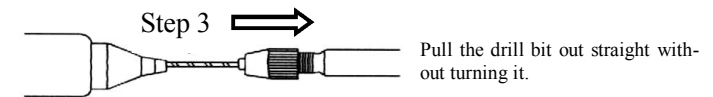
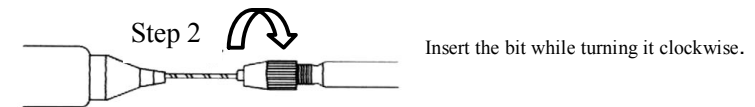

Caution: If the cleaning drill is forced into the nozzle, the drill bit could break or be damaged.

Please use the proper sized cleaning pin or cleaning drill for the nozzle diameter. If the cleaning pin cannot pass through the hole, replace the heating element.

Removing/replacing the Nozzle.

Unscrew the securing nut and pull out the heater external housing together with the securing lock, Nozzle can now be changed. Re-secure nozzle by tightening the securing lock on its receptacle.

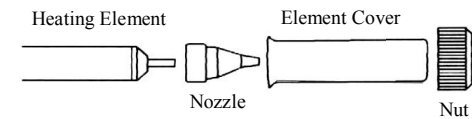

MAINTENANCE

Desoldering Gun Disassembled

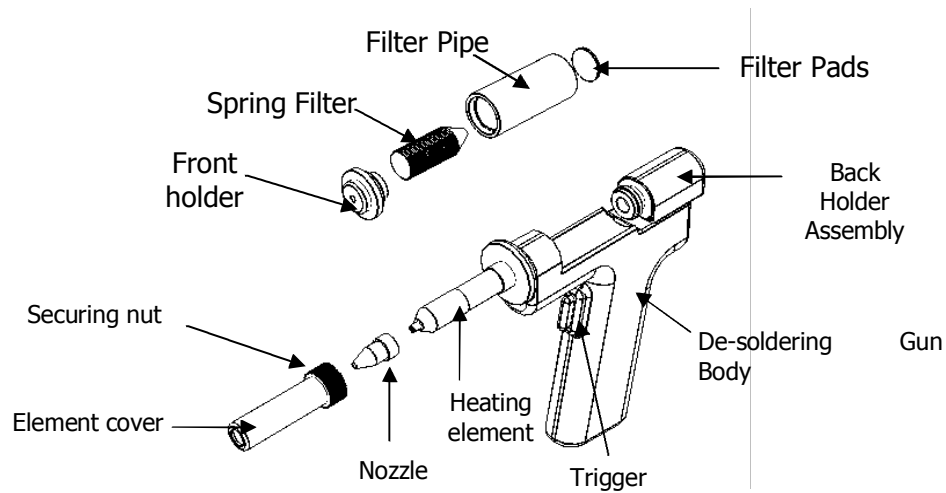

Replacing the filters.

1. Unlock the filter pipe by toggling the release knob. The back holder assembly would push out to allow easy extraction of the filter pipe assembly which houses the filter pad, filter spring and Front holder.
2. Take out the filter spring or the filter pads for cleaning or replacement.
3. Re-assemble Filter pipe assembly and place back to the de-soldering gun body.
4. Push the Filter dock back in place until a "click" sound is heard signifying that the filter dock is properly secured.

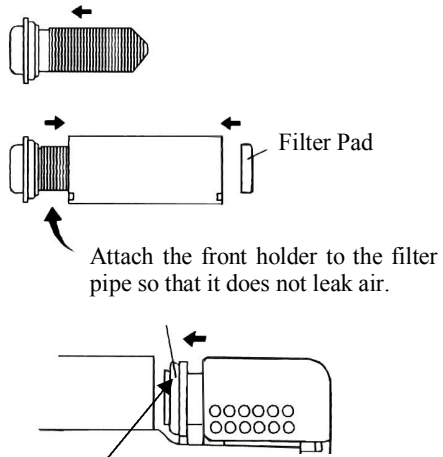

Attach the front holder to the filter pipe so that it does not leak air.

Press down release knob to unlock Back holder assembly

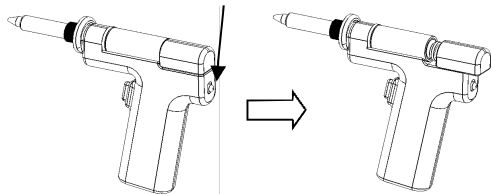

Firmly press the back holder assembly into the filter pipe in order to properly seat the o-ring against the pipe.

if Solder is collected in two-thirds of the spring filter replace the spring filter.

Replace Filter if stiff with flux and solder.

TABLE OF CONTENTS

<i>Precautions</i>	4
<i>Tip Care and Use</i>	5
<i>General Guidelines</i>	6
<i>Desoldering Gun Illustration</i>	7
<i>Operating Guidelines</i>	8-9
<i>Maintenance</i>	10-12

PRECAUTIONS

IMPORTANT

When the power is on, the tip and the nozzle temperature can be between 200°C / 392°F and 480°C / 896°F. Mishandling may lead to burns or fire, be sure to comply with the following precautions. To prevent damage to the unit and ensure a safe working environment, Be sure to comply with the following precautions:

- Do not touch the metallic parts near the tip and the nozzle, nearby plastic parts and the iron holder.
- Do not use the product near flammable items.
- Advise other people in the work area that the unit can reach a very high temperature and should be considered potentially dangerous.
- Turn the power off while taking breaks and after using the unit.
- Before replacing parts or storing the unit, turn the power off and allow the unit to cool to room temperature.
- Do not use the unit for applications other than desoldering.
- Do not tap the desoldering gun against the workbench to shake off residual solder, or subject the gun to sever shocks.
- Do not modify the unit.
- Use only our genuine replacement parts.
- Keep unit dry and away from liquids.
- Do not use the unit when your hands are wet.
- Do not forget to place the filters for the unit and air suction gun.

OPERATING GUIDELINES

5. Absorb the solder.

- After confirming that the solder is completely melted, absorb the solder by squeezing the trigger on the gun.
- Never leave any solder remaining inside the hole in the P.W.B.
- After fully absorbing all the solder, cool the soldering junction in order to prevent it from becoming re-soldered.

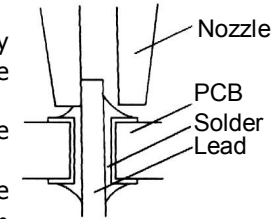

6. Problems during desoldering

If solder remains, re-solder the component and repeat the desoldering process.

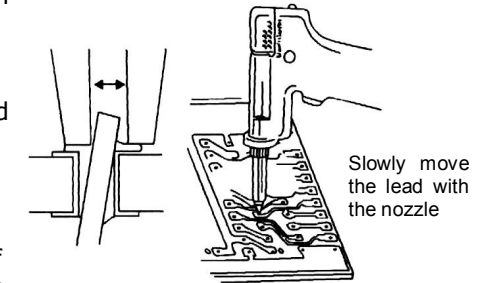

Cleaning during Operation

1. Observing the indicator and with the hole of the nozzle open, pull the trigger and look at the indicator. If it is red, clean the nozzle and heating element, empty the filter pipe, and replace the filters, If the indicator is blue, cleaning is not necessary and operations can be resumed.
 - The indicator will not operate accurately if the hole of the nozzle is closed or if the solder in the hole of the P.W.B. is not melted.
 - If there is a noticeable drop in suction efficiency, clean the nozzle and heating element with the cleaning pin.
2. Replacing the filter
 - Replace the filter as shown ①-③.
 - During operation, the filter pipe is very hot. wait until the filter pipe is cool before replacing the filter.

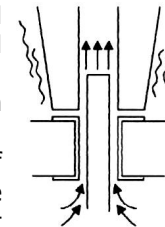

Absorb the solder by slowly moving the lead back and forth with the tip of the nozzle.

Normal	Abnormal	Solution
		If the indicator is more than half red, replace the filter and clean the nozzle and the inside of the heating element.
Blue or slight amount of red can be seen.	More than half of the indicator is red.	

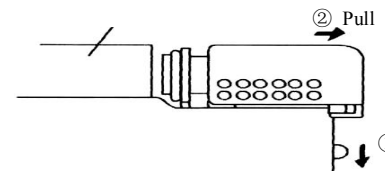

Use a preheating oven or heating gun to heat the PCN to a temperature that won't damage the board or its components [between 70°C(160°F) and 80°C(180°F)]. Then desolder. Do not increase the temperature of the gun by recalibration as this may damage the PCB, and its components.

OPERATING GUIDELINES

1. Connections

- Connect the cord assembly of the desoldering gun to the desoldering gun receptacle.
- Connect the hose to the vacuum outlet cap .
- Plug the power cord into the power supply.

CAUTION:

Confirm that the power switch is set in the OFF Position, then connecting the power plug to the power source.



Insert the cord assemble by keying the plug to the key on the receptacle.
Secure the plug by turning it clockwise.

2. Power switch

- Turn the power switch
- Turn the switch for desoldering gun to ON .
- The nozzle Begins to heat up as soon as the switch is turned ON
- Wait a few minutes or until Nozzle is hot enough to melt solder before beginning desoldering operations.

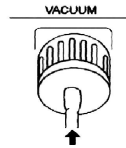

Fully insert the vacuum tube in the vacuum outlet cap.

3. Setting the temperature

- Always set the temperature to the lowest possible working temperature enough to melt the solder.

4. Clean the tip of the nozzle.

- Keep the solder-plated section of the nozzle a shiny white by coating it with a Small amount of solder.
- If the tip of the nozzle is coated with oxide, the nozzle's heat conductivity will be lowered. Coating the tip with a small amount of fresh solder ensures maximum heat conductivity.

Important: Always place the desoldering gun in its holder when not in use.

5. Melt the solder.

- Apply the nozzle to the soldered part and melt the solder.
- Never allow the nozzle to touch the Board itself.
- Confirm that the solder is melted, to confirm that all the solder is melted, observe the inside of the hole and the backside of the P. W. B. If this is difficult to do, try slowly moving the lead with the nozzle-if the lead moves, the solder is melted.
- Never move the lead by force .If it doesn't move easily, the solder is not fully melted.

TIP CARE AND USE

Tip Temperature

High soldering temperatures can degrade the tip. Use the lowest possible soldering temperature. The excellent thermal recovery characteristics ensure efficient and effective soldering even at low temperatures. This also protects the soldered items from thermal damage.

Cleaning

Clean the tip regularly with a cleaning sponge, as oxides and carbides. From the solder and flux can form impurities on the tip. These impurities can result in defective or reduce the tip's heat conductivity, When using the soldering iron continuously, be sure to loosen the tip and remove all soldering iron continuously, be sure to loosen the tip and remove all oxides at least once a week. This helps prevent seizure and reduction of the tip temperature.

When not in use

Never leave the soldering iron sitting at high temperature for long periods of time, as the tip's solder plating will become covered with oxide, which can greatly reduce the tip's heat conductivity

After usage

wipe the tip clean and coat the tip with fresh solder. This helps prevent tip oxidation.

GENERAL GUIDELINES

- Before usage dampen the filter pads with a little bit of water to allow efficient air passage and filter action, re-dampen pads frequently for maximum efficiency.



Filter Pads

- Routinely clean Spring Filter, and replace filter pads when they are dirty or clogged .



Filter Spring

- The solder pathway can be cleaned using the provided Nozzle cleaning pin, use the cleaning pin when pathway seems clogged.



Nozzle cleaning pin

DESOLDERING GUN

